

Features

- Operates in conjunction with fog light push-button on Karsan J9 vehicles
- Enables fog lights independent of ignition switch position

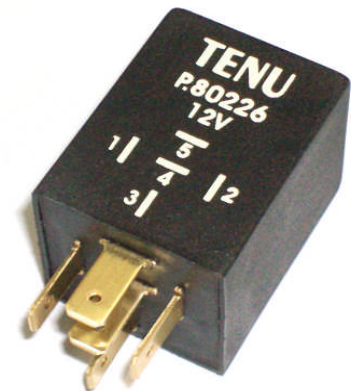

Electrical Connections

1	+12V from fog light push-button	0,80 x 6,40 male blade terminal
2	Chassis, battery negative	0,80 x 6,40 male blade terminal
3	+12V from battery	0,80 x 6,40 male blade terminal
4	+12V from ignition switch	0,80 x 6,40 male blade terminal
5	+12V relay output to fog lights	0,80 x 6,40 male blade terminal

Connection Diagram

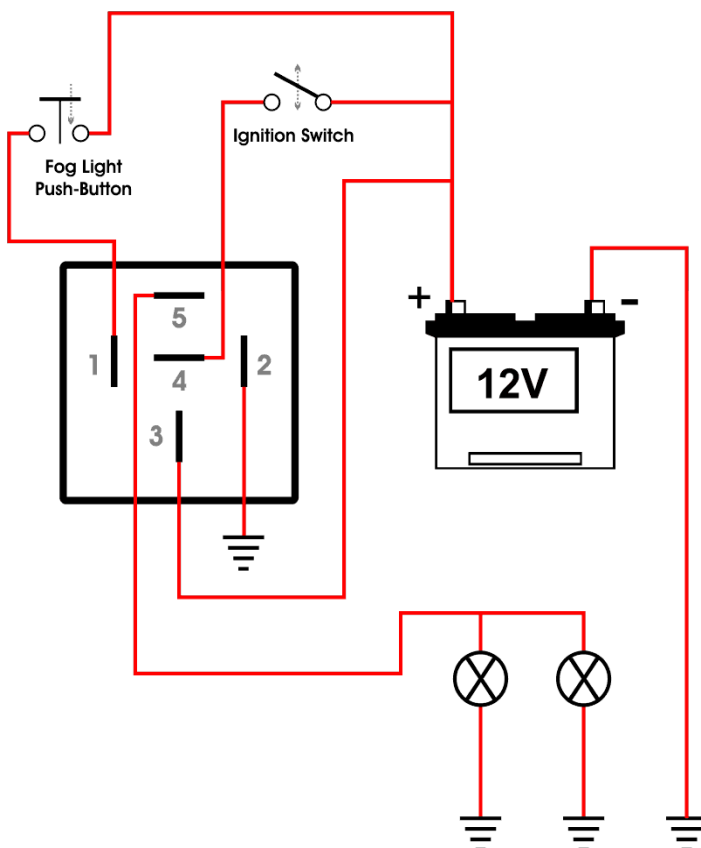

Operation Conditions

	<i>Minimum</i>	<i>Average</i>	<i>Maximum</i>	<i>Unit</i>
Voltage	10	-	15	V
Current output	-	-	15	A
Temperature	-30	-	85	°C

Dimensions (mm).

