

1. Features

- Operation of single or double wing passenger doors on 12V or 24V vehicles including door lock in compliance with automotive safety regulations.
- Auto-detection of battery voltage. No extra setting for 12V or 24V operation.
- Motor soft-start, soft-stop and speed adjustment with PWM
- Continuous motor current monitoring and parametric motor overcurrent protection in extreme load or stall conditions
- Short circuit and overheating protected outputs
- Vehicle speed monitoring and functionality according to ECE R107 requirements
- ECE R10 (EMC) and ISO 16750 certifications pending
- Software configurable inputs to detect positive or negative signals
- Four analogue configurable inputs
- Re-programmable by door manufacturer
- AEC qualified semi-conductor components
- After-sales logging of door operations (optional)
- RF remote control, CAN and Bluetooth connectivity (optional)

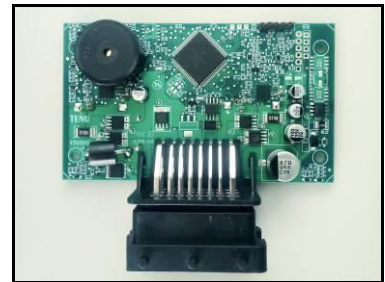

2. Absolute Maximum Ratings

DC Voltage (Battery and all inputs)	32	V
Door Wing Motor Current^{1,2} (On pins A1, B1, A8, B8)	15	A
Door Lock Motor Current¹ (On pins A2, A3)	3,20	A
Warning outputs¹ (On pins C6, C7)	0,50	A
Operating temperature	-40 / +125	°C

¹ Characterized at 14V, not tested

² Safe operation continuous current. Momentary currents up to 70A are permitted.

3. Operating Conditions

	Minimum	Typical	Maximum	
DC Voltage (Battery)	9	-	32	V
Door Wing Motor Current¹	14,25	15	15,75	A
Positive Input Voltage	9	-	-	V
Positive Input Sink Current²	1,58	1,80	2,02	mA
Positive Input Sink Current³	4,23	4,80	5,40	mA
Negative Input Voltage	-	-	0,75	V
Negative Input Source Current⁴	-65	-115	-185	µA
Standby Current (No input)	-	-	17	mA

¹ Limited by software

² At 14V

³ At 28V

⁴ When directly connected to battery negative

4. Connector

Seco: SC-B004.12 (Black)

Mating Connector

Seco: SC-B004.02

Delphi/FCI: 211 PC249S00xx

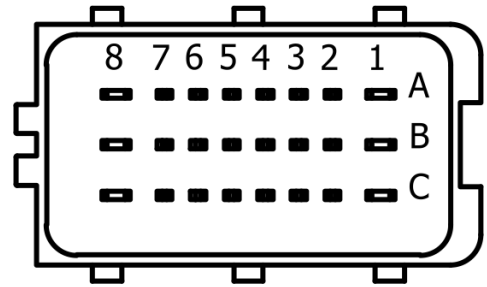

5. Wiring Diagram

Common wiring for double wing door with 4585.

The functionality of all pins can be re-designed by software.

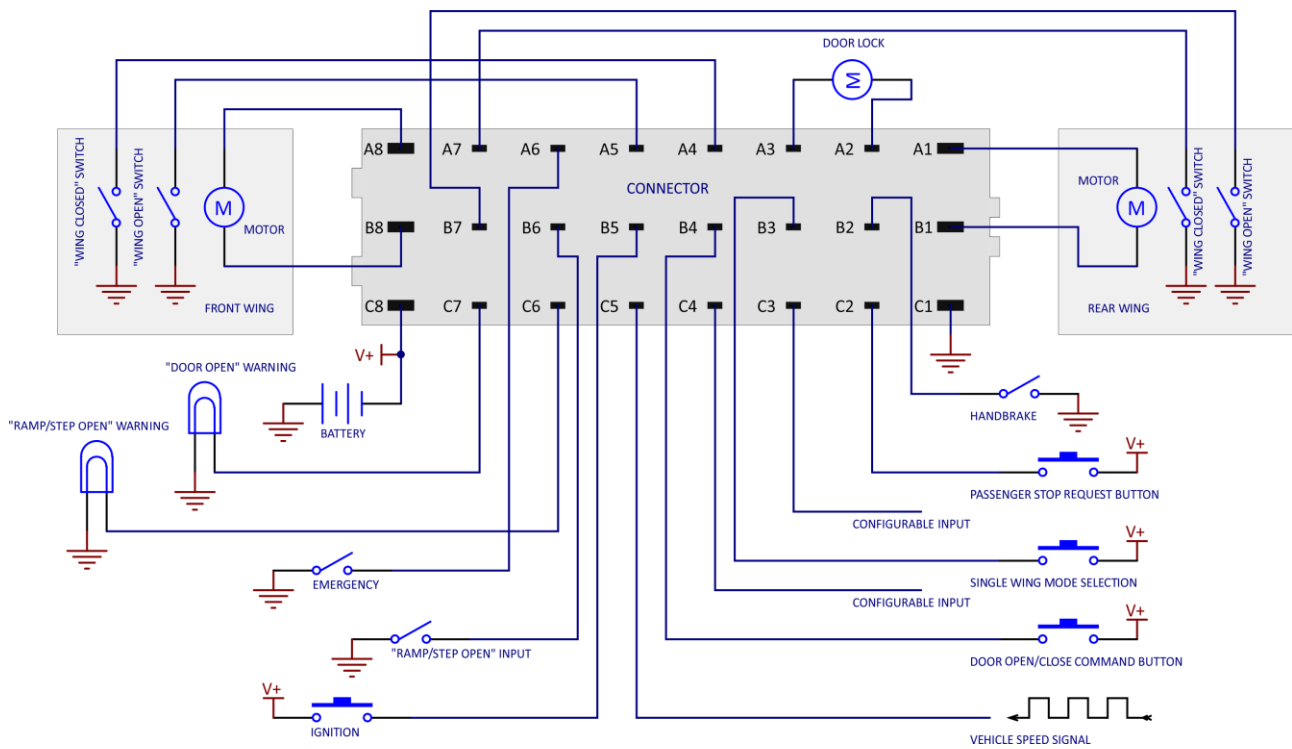

6. Pin Functions

A1	Rear Wing Motor Output A (H-Bridge)
A2	H-Bridge Door Lock Motor Output A: Locks door depending on vehicle speed signal
A3	H-Bridge Door Lock Motor Output B: Locks door depending on vehicle speed signal
A4	“Front Wing Closed” switch input: This switch must be mounted in such a way that it is activated a little distance before the wing reaches its fully closed position. While closing, the front wing slows down when this switch closes circuit. Alternatively, this pin is configurable as an analogue input.
A5	“Front Wing Open” switch input: If used, this switch must be mounted in such a way that it is activated a little distance before the wing reaches its fully open position. While opening, the front wing slows down when this switch closes circuit. Alternatively, this pin is configurable as an analogue input.
A6	Emergency input: Input from the switch connected to the emergency exit handle. When the emergency handle is pulled, motors are disabled and an intermittent audible warning from the module’s internal buzzer is activated.
A7	“Rear Wing Open” switch input: If used, this switch must be mounted in such a way that it is activated a little distance before the wing reaches its fully open position. While opening, the rear wing slows down when this switch closes circuit. Alternatively, this pin is configurable as an analogue input.
A8	Front Wing Motor Output A (H-Bridge)
B1	Rear Wing Motor Output B (H-Bridge)
B2	“Handbrake pulled” input: Opening the door is not permitted unless handbrake is pulled. If handbrake is released while the door is open or opening, this will trigger the motors to shut the door.
B3	Single wing mode input: When this input is active, only the front wing is enabled to run. Changes made on this input will not take effect unless both wings of the door are closed.
B4	Door command input: Dashboard Open/Close command button for the door.
B5	Ignition input: Handbrake and ramp/step inputs are disabled when ignition is off. That is, the door can be operated free by remote control.
B6	“Ramp/Step Open” input: Used in order to detect whether the disabled passenger entry ramp or door step is open. When open, the door cannot be closed unless the ramp/step is closed.
B7	“Rear Wing Closed” switch input: This switch must be mounted in such a way that it is activated a little distance before the wing reaches its fully closed position. While closing, the rear wing slows down when this switch closes circuit. Alternatively, this pin is configurable as an analogue input.
B8	Front Wing Motor Output B (H-Bridge)
C1	12V/24V Battery -
C2	“Passenger Stop Request” input: A signal on this input activates C6 output when the door is closed. C6 remains ON until the door is opened.
C3	Communication pin. Alternatively, software configurable as an input, hardware configurable as CANH.
C4	Communication pin. Alternatively, software configurable as an input, hardware configurable as CANL.
C5	Vehicle speed signal: This input reads the square wave speed signal from the vehicle electrical system. Opening the door is not permitted unless the vehicle is at full rest.
C6	Passenger stop request signal output: Triggered by B6 input. Maximum 3W.
C7	“Door open” signal output: Active unless both wings are closed in order to indicate that the door is open. Maximum 3W.
C8	12V/24V Battery +

7. Appearance and Weight

Body	Black anodized aluminium
Mounting brackets	Black anodized aluminium
Weight	190 gram

8. Dimensions

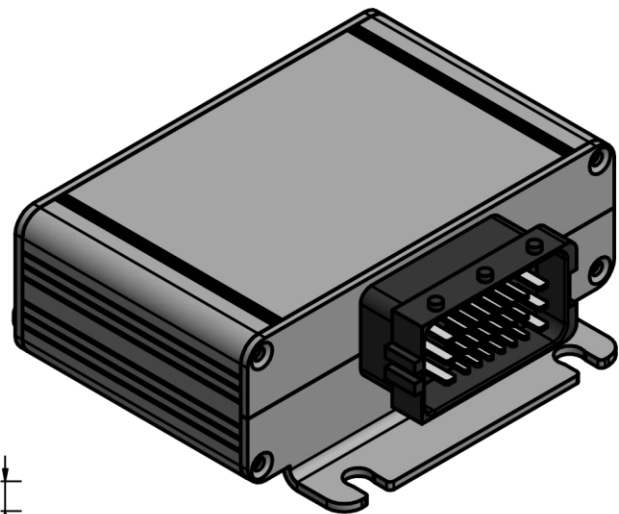
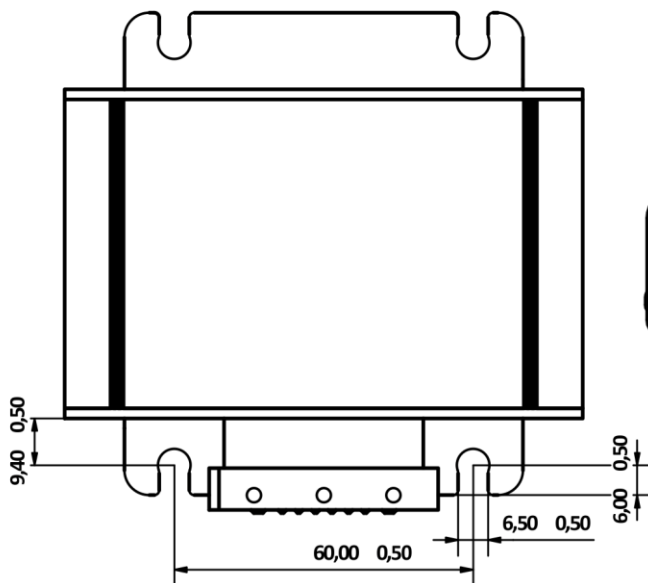
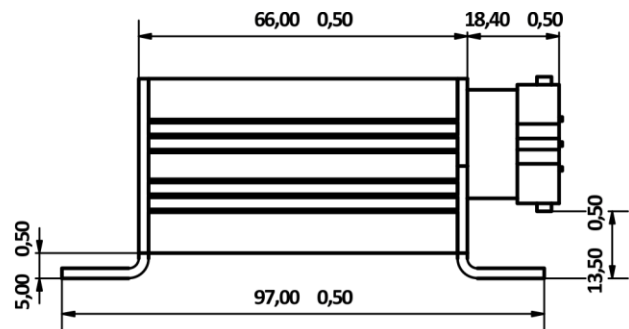
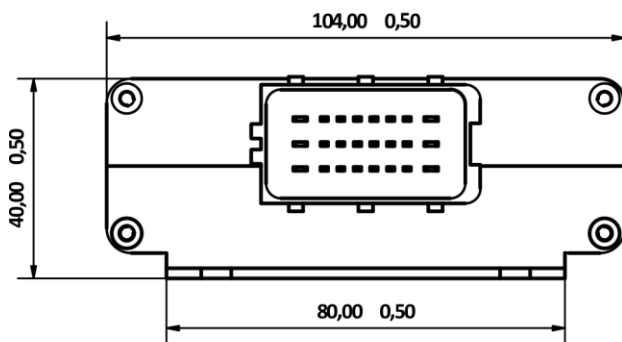

9. Ordering Options

4585A	Double wing door. No door lock output.
4585B	Double wing door with door lock outputs.
4585C	Single wing door. No door lock output.
4585D	Single wing door with door lock outputs.
xxxxx-C	C suffix. CAN available.
xxxxx-R	R suffix. RF remote control available.
xxxxx-BL	BL suffix. Bluetooth available.

10. Software Options

Software options can be defined with customer based on project requirements. This document is based on software 9.00 as a recommendation only.

11. Revisions

REVISION	DATE	DESCRIPTION
*	27.03.2019	Initial release