

TENU 3513 Intermittent Wiper Relay implements intermittent wiping and wipe-wash functions on VW vehicles.

Wiper motors can draw excessive currents due to snow load in winter. TENU wiper relays include an internal relay able to withstand such high currents.

Continuous operation of wipers is independent of wiper relay.

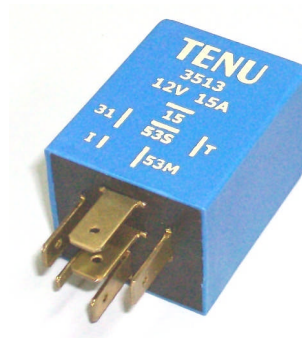

Features

- 6 seconds interval in intermittent mode
- 3 successive wiper operations after windscreen washer operation (wipe-wash)

Intermittent Operation

When the wiper lever is brought to intermittent position, wipers operate one time and stop. If the lever is left in the same position, wipers keep running with 6 seconds intervals. If intermittent operation is switched off and back on immediately, wipers start running again without delay.

Windscreen Washing

At any point of operation, if the windscreen washer is run, wipers operate 3 times successively after windscreen washer button is released.

Electrical Connections

I	+12V from wiper lever at intermittent position	0,80 x 2,80 male blade terminal
53M	+12V relay output to wiper motor winding	0,80 x 6,40 male blade terminal
31	Chassis, battery negative	0,80 x 6,40 male blade terminal
53S	12V positive or negative input from wiper motor park switch	0,80 x 6,40 male blade terminal
T	+12V from washer pump button	0,80 x 6,40 male blade terminal
15	+12V from ignition switch	0,80 x 6,40 male blade terminal

Connection Diagram

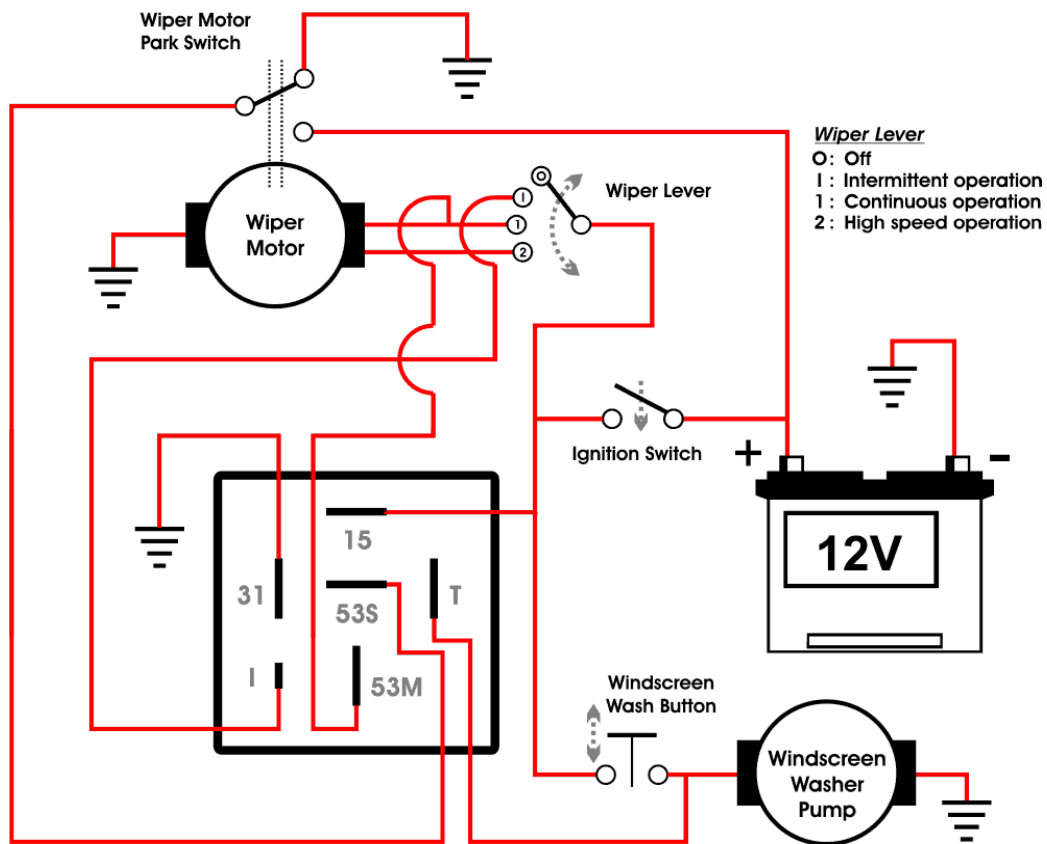

Operation Conditions

	Minimum	Average	Maximum	Unit
Voltage	10	-	15	V
Current output	-	-	15	A
Temperature	-30	-	85	°C
Interval	5,4	6	6,6	Seconds

Dimensions (mm)

